

MASS:	TOLERANCES-UNLESS OTHERWISE SPECIFIED 2 PL. DEC. ±.010 TRUE C.L. ±.015 3 PL. DEC. ±.005 ANGLES ±1	DWG. NO.	
CAT. NO.:		M2694	
	DRAWN BY: CLH	SCALE: 1:1	SHEET 1 OF 1
	DATE: 7/23/2008	SIZE: A	

REV.	DESCRIPTION
I	

Cat #: DBK-2

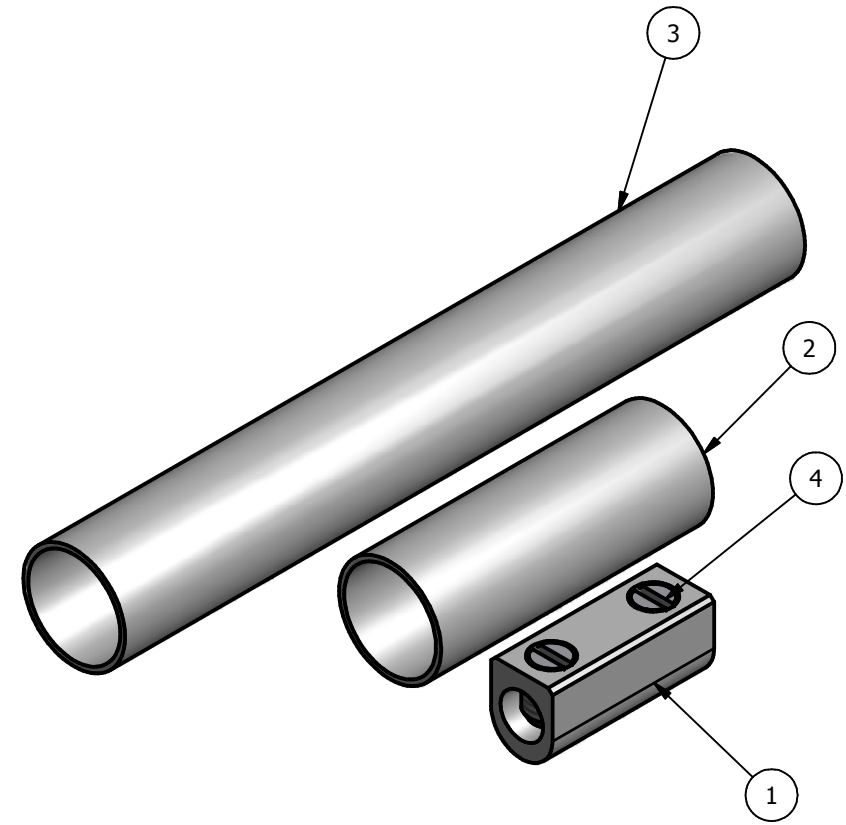

Parts List			
ITEM	QTY	PART NUMBER	DESCRIPTION
1	1	D8680C20T	CONNECTOR
2	1	R0914C00A	2" SHRINK TUBE
3	1	R0911C00A	5" SHRINK TUBE
4	2	E0309C92Z	5/16-24 X .410 SCREW